

RC3

GAMING CHAIR

Version 2.0

RC3UNI-11 , RC3UNI-12

ACTIVATE YOUR PRODUCT WARRANTY:
WWW.GIOTECK.COM/REGISTER

IMPORTANT : To help ensure risk-free operation please read these Operational and Safety Guidelines before use:

- For indoor use only. Do NOT expose to direct sunlight, moisture or extreme temperatures.
- Children under 13 should not use this product without parental supervision. Adult supervision is required for set-up.
- Do NOT use on slippery or uneven flooring.
- Excessive use of audio equipment at high volume may lead to hearing loss. Listen responsibly and use common sense.
- Do NOT wash or soak the unit with water. If cover becomes wet, disconnect power immediately and do not use until it's totally dry.
- Store in a dry & dust free area.
- Do not store in areas of extreme low (0°C) or high (40°C) temperatures.
- Do not allow the product to get wet or dirty; doing so may cause damage.
- Do not take the product apart; doing so will void your warranty and may cause electrical shock or damage to internal components.



Please help to conserve the environment by recycling the cardboard packaging of this product.



This product should NOT be disposed of in normal household waste. It should be disposed of separately. Please take it to an electrical waste collection point.

For help with the set-up or operation
of this product please go to :

gioteck.com/contact-support

PARTS

- i) Chair
- ii) 3.5mm to RCA adapter
- iii) 3.5mm mini audio cable
- iv) DC adapter 9V 600mA

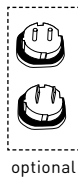
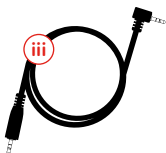
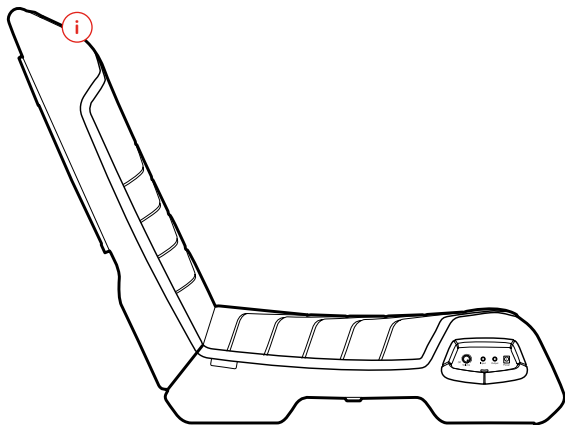

CONTROLS

Power On/Off and Volume +/-

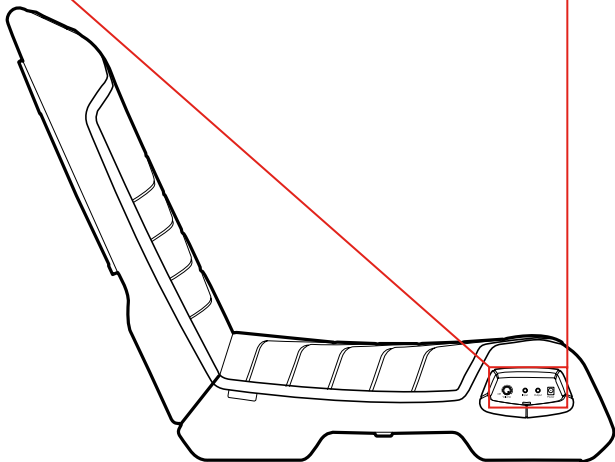
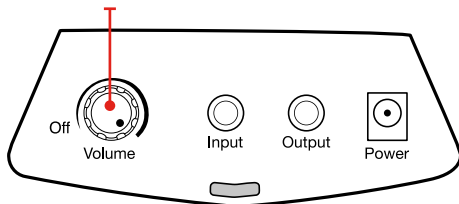

BACK ADJUSTMENT

For a more relaxed seat position. Remove the red block from under the back of the chair as shown,

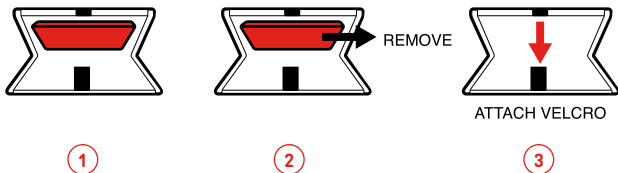
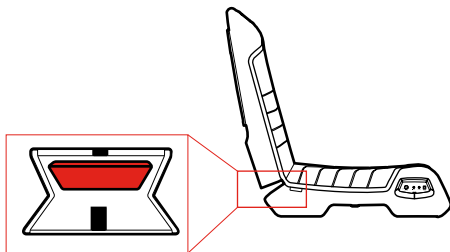
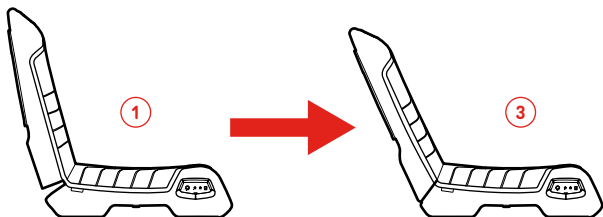

1. CONNECTION TO XBOX 360™, PS3™, WII™

- 1) Connect the RCA cable to your chosen VIDEO INPUT source (A).
- 2) Connect the red and white ends of the RCA cable (not included, but usually provided with your game console) into the corresponding ports of the RCA adapter (B). The other end of this cable is plugged into the AV Socket on your Xbox.
- 3) Connect one end of the mini audio cable into the RCA adapter (C) and the other end into the INPUT socket on the control panel (D).

Note to Xbox 360™ Users: Depending on the model of your console and if your console is connected via HDMI to a video source, you will need to obtain an AV RCA adapter and use a male to male RCA cable such as that shown in set up 2A below.

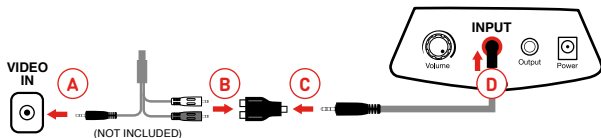

2A. CONNECTION TO XBOX ONE™, PS4™, TV, DVD, RECEIVER

- 1) Connect the male to male RCA cable (not included) to your chosen AUDIO OUT source (A).
- 2) Connect the other ends of the RCA cable into the corresponding ports of the RCA adapter (B).
- 3) Connect one end of the mini audio cable into the RCA adapter (C) and the other end into the INPUT socket on the control panel (D).

Note all TV/Monitors have Left & Right Audio Out. Look on the back of your TV/Monitor and see if it has a Headphones Out socket. If your TV has a Headphones Out A, B and C are not required for this setup and the audio cable supplied with the chair can be plugged directly into the TV headphone socket.

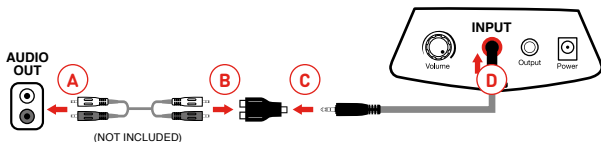

2B. CONNECTION TO PS4™ & XBOX ONE™

Connect one end of the mini audio cable into the controller socket (A) and the other end into the INPUT socket on the control panel (D).

- Sound will be quieter using this setup compared to setup 2A.
- Ensure you are using a Microsoft® Headset Stereo Adapter with your Xbox One™ controller.
- If using the PS4™ system you will need to change the settings on your console: Settings > 'Chat Only' to 'All Sound'.

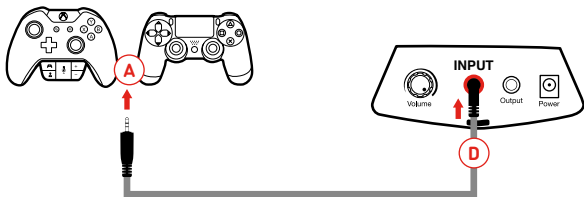

3. CONNECTION TO HANDHELD DEVICE / IPOD / MP3

Connect one end of the mini audio cable into the headphone socket (A) of your handheld device/iPOD/MP3 Player and the other end into the INPUT socket on the control panel (D).



4. CONNECTION TO MULTIPLE CHAIRS

Connect one end of the mini audio cable into the INPUT Socket of Chair 1 (D) and the other end into the OUTPUT socket of Chair 2 (E).

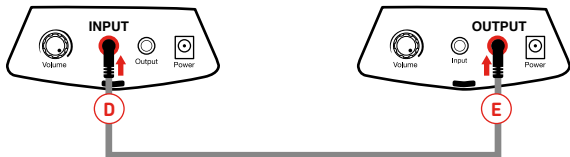

TROUBLESHOOTING GUIDE

NO SOUND CAN BE HEARD FROM THE RC-3 GAMING CHAIR

- 1] Is the gaming chair turned on?** Check to ensure gaming chair power is on by adjusting the volume knob on the control panel and the LED light will illuminate.
- 2] Is the audio cable connected properly?** Check your cable connection carefully and make sure all cables are securely connected according to the Connection Guide. For connecting the gaming chair to the TV or AV source, the RCA Cables (not included) **MUST** be connected to the Audio or Headphones Output of your TV or AV source.
- 3] Adjust the Volume knob to ensure audio is at an audible level.**
- 4] Test with an alternative audio source (CD player, TV, MP3, etc.)**

If after completing all of the steps above and there is still no sound, please contact us for assistance.

This product is covered by a one [1] year warranty.
For full Terms and Conditions, and for Technical Assistance, go to :
gioteck.com/contact-support

Australia only - Regulation 90

This product is manufactured by GoodBetterBest ("GBB") of the United Kingdom. Our goods come with guarantees that cannot be excluded under the Australian Consumer Law. You are entitled to a replacement or refund for a major failure and for compensation for any other reasonably foreseeable loss or damage. You are also entitled to have the goods repaired or replaced if the goods fail to be of acceptable quality and the failure does not amount to a major failure. GBB warrants to the original consumer purchaser that the product will be free of defects in materials and/or workmanship for the length of time specified in the warranty period from the date of purchase, this being 1 Year, as set forth at : www.gioteck.com/contact-support

If a defect covered by this warranty occurs during the warranty period, GoodBetterBest at its option will repair or replace, at no charge, any part that GoodBetterBest determines to be defective. To make a warranty claim please contact GBB's Australian distributor, Turn Left Distribution at : helpdesk@turnleft.biz Turn Left Distribution is responsible for the servicing of warranty claims for purchases made in Australia. The purchaser will be required to bear the expense of sending the product back to the Australian distributor to claim the warranty. If you are unable to satisfactorily resolve your issue with the retailer, please contact GBB through its website at : www.gioteck.com/contact-support or alternatively, you can contact GBB directly at: GBB Limited, 103 Devonshire Business Centre, Works Road, Letchworth, SG6 1GJ, United Kingdom.

This warranty shall not apply if the product has been damaged by abuse, misuse, negligence, accident, modification, tampering or by any causes unrelated to defective materials and/or workmanship. Repair or replacement as provided under this warranty is GoodBetterBest exclusive prerogative. In order to obtain warranty services under certain circumstances (particularly when the retailer will not accept the return of the defective product), you may be required by GBB to return the product directly to GBB in the United Kingdom for inspection and evaluation, along with evidence of purchase (including the price paid and the date the item was purchased), for a determination of whether the warranty applies. If you have been asked by GBB to return the product to GBB in the United Kingdom, and the product is defective and covered under the applicable warranty period, GBB shall provide the appropriate warranty services. If the warranty does not apply (either due to misuse, damage, negligence, etc., or because the warranty period has expired), you may be charged to return the product to you (if you instruct us to do so). Any applicable implied warranties, including warranties or merchantability and fitness for a particular purpose are hereby limited to the length of time specified in the warranty periods below, beginning from the date of purchase and are subject to the conditions set forth in this limited warranty.

In no event shall GoodBetterBest be accountable for incidental damages resulting from the breach of any express or implied warranties. You may have different or additional legal rights, including longer warranty periods, which vary from jurisdiction to jurisdiction. Some jurisdictions do not allow certain limitations on how long an implied warranty lasts, so the above limitations may not apply to you. In addition, consumers have legal rights under applicable national legislation governing the sale of consumer goods. Such rights are not affected by the warranties set forth herein, except to the extent allowed by law.

WICHTIG: Um den gefahrenfreien Betrieb zu gewährleisten, lesen Sie vor der Verwendung des Produkts bitte diese Bedienungs- und Sicherheitsrichtlinien sorgfältig durch:

- Nicht im Freien verwenden. NICHT dem direkten Sonnenlicht, Feuchtigkeit oder extremen Temperaturen aussetzen.
- Kinder unter 13 Jahren sollten dieses Produkt nur unter Aufsicht eines Erwachsenen verwenden. Inbetriebnahme des Produkts NUR unter Aufsicht eines Erwachsenen.
- NICHT auf rutschigem oder unebenem Boden verwenden.
- Die exzessive Verwendung von Audiogeräten bei hoher Lautstärke kann Hörschäden hervorrufen. Verwenden Sie dieses Produkt verantwortungsvoll und mit gesundem Menschenverstand.
- Waschen oder weichen Sie das Produkt NICHT mit Wasser ein. Wenn das Produkt nass wird, ziehen Sie sofort den Netzstecker und verwenden Sie es erst wieder, wenn es vollkommen trocken ist.
- Trocken und staubfrei lagern.
- Nicht bei extrem niedrigen (0°C) oder extrem hohen (40°C) Temperaturen lagern.
- Verhindern Sie, dass das Produkt nass oder schmutzig wird – es könnte sonst beschädigt werden.
- Bauen Sie das Produkt nicht auseinander. Andernfalls erlischt die Garantie. Zudem könnten Sie einen Stromschlag bekommen oder es könnten interne Bauteile beschädigt werden.



Bitte helfen Sie, die Umwelt zu schützen, indem Sie die Kartonverpackung dieses Produkts recyceln.



Dieses Produkt sollte NICHT im normalen Haushaltsmüll entsorgt werden. Es sollte separat entsorgt werden. Bitte geben Sie es an einer Sammelstelle für Elektromüll ab.

Wenn Sie Hilfe bei der Inbetriebnahme oder beim Betrieb dieses Produkts benötigen, besuchen Sie bitte

giotek.com/contact-support

TEILELISTE

- i) Stuhl
- ii) 3,5-mm-auf-Cinch-Adapter
- iii) 3,5-mm-Mini-Audiokabel
- iv) Netzadapter 9 V 600 mA

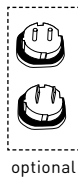
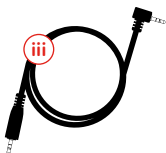
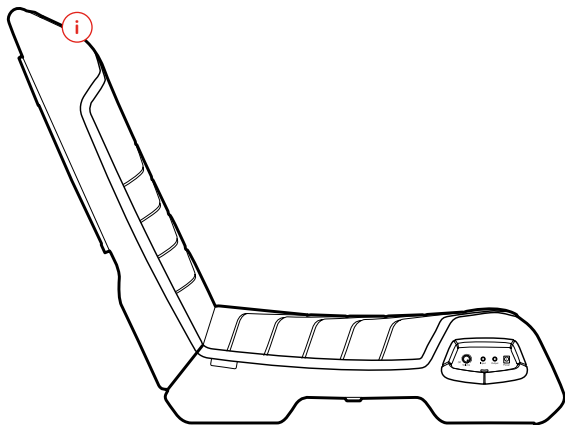

ANSCHLÜSSE/BEDIENUNG

DE

Ein-/Ausschalten und Lautstärke +/-

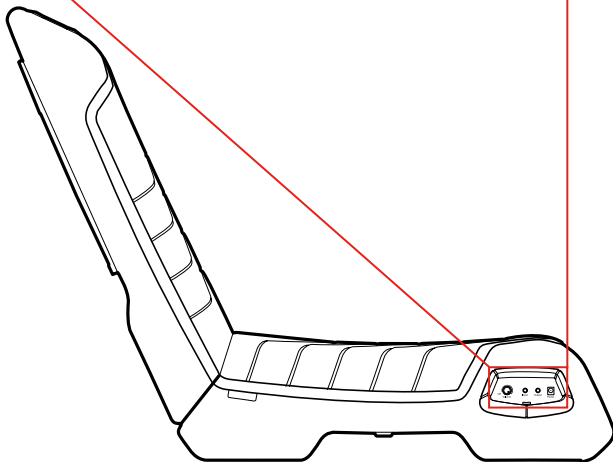
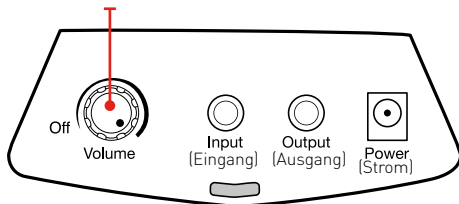

RÜCKENLEHNE

Entfernen Sie für eine entspanntere Sitzposition wie auf der Abbildung den roten Block.

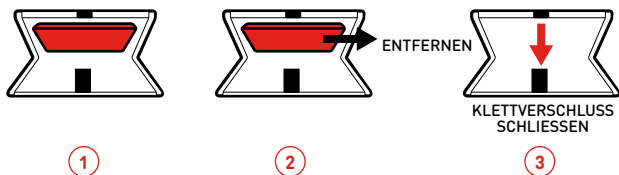
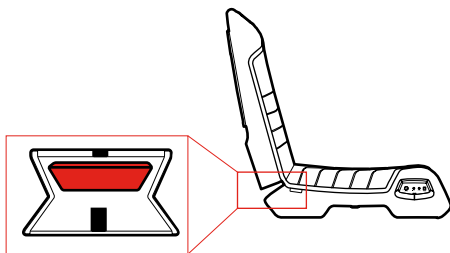
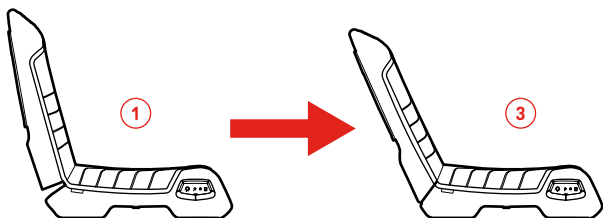

1. VERBINDUNG MIT XBOX 360™, PS3™, WII™

- 1) Verbinden Sie das Cinch-Kabel mit Ihrer gewünschten Video-Eingangsquelle (A).
- 2) Verbinden Sie das rote und das weiße Ende des Cinch-Kabels (nicht mitgeliefert, meistens aber im Lieferumfang Ihrer Konsole enthalten) mit den entsprechenden Anschlüssen des Cinch-Adapters (B).
- 3) Verbinden Sie ein Ende des Mini-Audiokabels mit dem Cinch-Adapter (C) und das andere Ende mit dem INPUT-Anschluss des Stuhls (D).
Stecke das andere Ende dieses Kabels in den AV-Anschluss deiner Xbox.

Hinweis für Xbox 360™ -Benutzer: Je nach Modell Ihrer Konsole und abhängig davon, ob Ihre Konsole per HDMI mit einer Videoquelle verbunden ist, müssen Sie eventuell einen AV-Cinch-Adapter kaufen und ein Stecker-auf-Stecker-Cinch-Kabel wie in Setup 2A unten gezeigt verwenden.

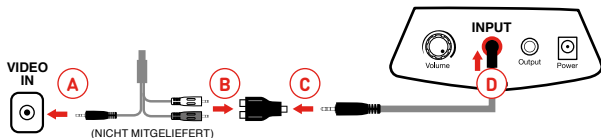

2A. VERBINDUNG MIT XBOX ONE™, PS4™, TV, DVD-SPIELER, RECEIVER

- 1) Verbinden Sie das Stecker-auf-Stecker-Cinch-Kabel (nicht mitgeliefert) mit Ihrer gewünschten Audio-Ausgangsquelle (A).
- 2) Verbinden Sie die anderen Enden des Cinch-Kabels mit den entsprechenden Anschlüssen am Cinch-Adapter (B).
- 3) Verbinden Sie ein Ende des Mini-Audiokabels mit dem Cinch-Adapter (C) und das andere Ende mit dem INPUT-Anschluss des Stuhls (D).

Nicht alle TVs/Monitore besitzen separate linke und rechte Audioausgänge. Sehen Sie auf der Rückseite Ihres TVs/Monitors nach, ob er einen Kopfhörerausgang besitzt. Wenn dein Fernseher einen Kopfhörerausgang hat, sind die Schritte A, B und C für die Einrichtung überflüssig und können ignoriert werden, da das mitgelieferte Audiokabel direkt in den Kopfhörerausgang des Fernsehers gesteckt werden kann.

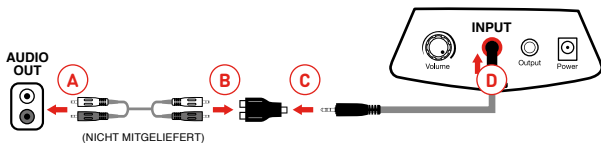

2B. VERBINDUNG MIT PS4™ & XBOX ONE™

Verbinden Sie ein Ende des Mini-Audiokabels mit dem Controller-Anschluss (A) und das andere Ende mit dem INPUT-Anschluss des Stuhls (D).

- Im Vergleich zu Setup 2A werden die Sounds bei diesem Setup etwas leiser abgespielt.
- Stellen Sie sicher, dass Sie einen Microsoft® Headset Stereo Adapter mit Ihrem Xbox One™ Controller verwenden.
- Bei der PS4™ müssen Sie die Einstellungen Ihrer Konsole anpassen: Einstellungen > Von 'Chat-Audio' auf 'Alle Sounds'.

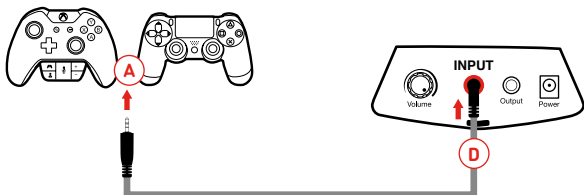

3. VERBINDUNG MIT MOBILGERÄT / IPOD / MP3-PLAYER

Verbinden Sie ein Ende des Mini-Audiokabels mit dem Kopfhöreranschluss (A) Ihres Mobilgeräts / iPods / MP3-Players und das andere Ende mit dem INPUT-Anschluss des Stuhls (D).

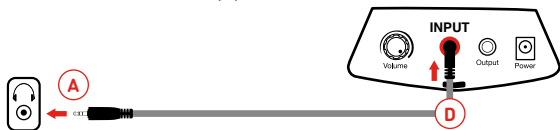

4. VERBINDUNG MIT MEHREREN STÜHLEN

Verbinden Sie ein Ende des Mini-Audiokabels mit dem INPUT-Anschluss von Stuhl 1 (D) und das andere Ende mit dem OUTPUT-Anschluss von Stuhl 2 (E).



PROBLEMLÖSUNGEN

DER RC-3 GAMING CHAIR GIBT KEINEN TON WIEDER

- 1] Ist der Gaming Chair eingeschaltet? Stellen Sie sicher, dass der Gaming Chair eingeschaltet ist, indem Sie den Lautstärkereglern am Stuhl drehen. Das LED-Licht leuchtet auf, wenn der Stuhl eingeschaltet ist.
- 2] Ist das Audiokabel richtig angeschlossen? Überprüfen Sie Ihre Kabelverbindung sorgfältig und stellen Sie sicher, dass alle Kabel wie in der Anleitung beschrieben angeschlossen sind. Um den Gaming Chair mit der TV- oder AV-Quelle zu verbinden, MÜSSEN die Cinch-Kabel (nicht mitgeliefert) mit dem Audio- oder Kopfhörerausgang Ihrer TV- oder AV-Quelle verbunden sein.
- 3] Passen Sie mit Hilfe des Lautstärkereglers die Lautstärke an, um sicherzustellen, dass sie auf einem hörbaren Pegel steht.
- 4] Testen Sie den Gaming Chair mit einer alternativen Audioquelle (CD-Player, TV, MP3-Player oder ähnliches).

Ist noch immer kein Ton zu hören, nachdem Sie alle diese Schritte ausgeführt haben, wenden Sie sich bitte an uns.

Dieses Produkt hat eine Garantie von einem [1] Jahr.

Die vollständigen Bedingungen und Konditionen sowie Technische Unterstützung erhalten Sie unter gioteck.com/contact-support

IMPORTANTE: para garantizar un uso adecuado y sin riesgos, lea estas instrucciones de funcionamiento y seguridad antes de utilizar el dispositivo.

- Solo para uso en interiores. NO exponga el producto a la luz solar directa, a la humedad ni a temperaturas extremas.
- Los menores de 13 años no deben utilizar este producto sin la supervisión de un adulto, incluida la fase de montaje.
- NO coloque el producto sobre superficies resbaladizas o irregulares.
- El uso prolongado de dispositivos de audio a volúmenes altos puede provocar pérdidas de audición. Asegúrese de ajustar el volumen de forma responsable y sensata.
- NO lave el producto con agua. Si las cubiertas se mojan, desconecte el producto de la toma de alimentación inmediatamente y espere a que se seque por completo.
- Almacene el producto en un lugar seco y sin polvo.
- No lo guarde en lugares con temperaturas extremadamente bajas (0 °C) ni altas (40 °C).
- No moje ni ensucie el producto; de lo contrario, podría dañarlo.
- No desmonte el producto, ya que la garantía quedará anulada y podría sufrir una descarga eléctrica o causar daños en los componentes internos.



Ayude a proteger el medio ambiente reciclando el embalaje de cartón del producto.



Este producto NO debe tirarse a la basura normal. Llévelo a un punto de recogida de desechos eléctricos.

Si desea más información sobre la instalación o el uso de este producto, visite el siguiente sitio web:

giotek.com/contact-support

PIEZAS

- i] Silla
- ii] Adaptador de 3,5 mm a RCA
- iii] Cable de audio mini de 3,5 mm
- iv] Adaptador de CC (9 V 600 mA)

ES

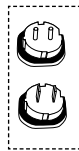
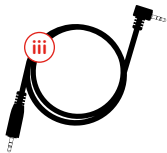
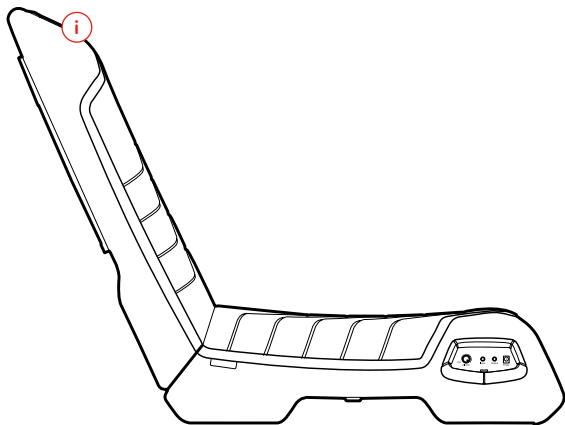

opcional

CONTROLES

Encendido/apagado y aumentar/reducir volumen

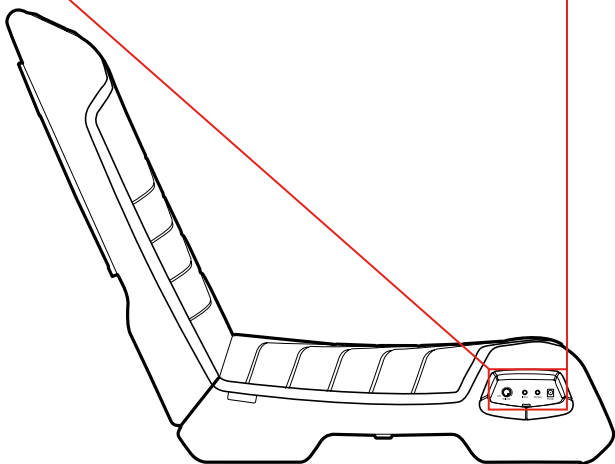
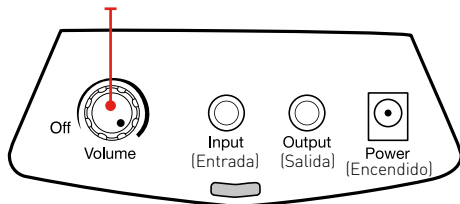

AJUSTE DEL RESPALDO

Para adoptar una postura de juego más cómoda, retire el bloque rojo situado debajo del respaldo como se muestra en la ilustración.

ES

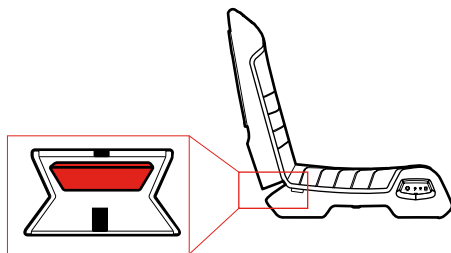
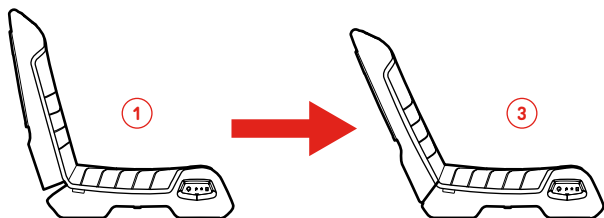

1. CONEXIÓN A XBOX 360™, WII™ Y PS3™

- 1] Conecte el cable RCA a la ENTRADA DE VÍDEO que desee (A).
- 2] Inserte los conectores rojo y blanco del cable RCA (no incluido, aunque suele suministrarse con los diferentes sistemas/consolas) en los puertos correspondientes del adaptador RCA (B).
- 3] Conecte un extremo del cable de audio mini al adaptador RCA (C) y el otro al conector de ENTRADA del panel de control (D). El otro extremo del cable se enchufa en el conector AV de la Xbox.

Advertencia para los usuarios de la consola Xbox 360™: en función del modelo de la consola y de si la conexión de vídeo se realiza por HDMI, puede que tenga que adquirir un adaptador RCA AV y utilizar un cable RCA macho-macho como el que se muestra en la imagen de configuración 2A.

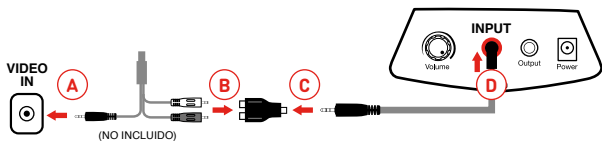

2A. CONEXIÓN A LA CONSOLA XBOX ONE™, PS4™, TELEVISOR, REPRODUCTOR DE DVD Y RECEPTOR

- 1] Conecte el cable RCA macho-macho (no incluido) a la SALIDA DE AUDIO que desee (A).
- 2] Inserte los otros extremos del cable RCA en los puertos correspondientes del adaptador RCA (B).
- 3] Conecte un extremo del cable de audio mini al adaptador RCA (C) y el otro al conector de ENTRADA del panel de control (D).

No todos los televisores ni monitores disponen de salidas de audio izquierda y derecha. Examine la parte trasera de su televisor o monitor y busque una salida apta para auriculares; Si su televisor dispone de una salida apta para auriculares, podrá prescindir de A, B y C en la instalación y conectar directamente el cable de sonido provisto con la silla en la entrada para auriculares del televisor.

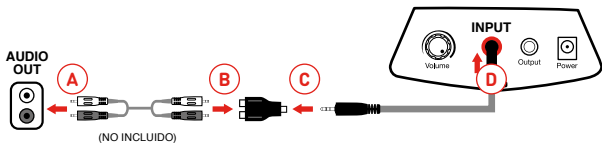

2B. CONEXIÓN A LA CONSOLA XBOX ONE™ Y PS4™

Inserte un extremo del cable de audio mini en el conector del mando (A) y el otro en el conector de ENTRADA del panel de control (D).

- Con esta configuración, el sonido se reproducirá a un volumen más bajo que con 2A.
- En el caso de la consola Xbox One™, asegúrese de utilizar el adaptador para auriculares estéreo de Microsoft® con el mando.
- En el caso del sistema PS4™, cambie los ajustes como se indica a continuación: Ajustes > Cambio de 'Audio del chat' a 'Todo el audio'.

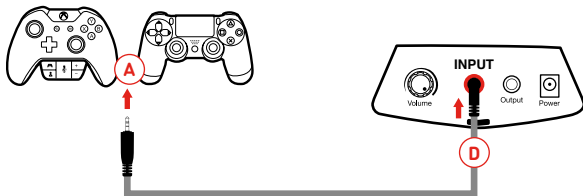

3. CONEXIÓN A UN DISPOSITIVO PORTÁTIL / IPOD / REPRODUCTOR DE MP3

Conecte un extremo del cable de audio mini al conector (A) para auriculares de su dispositivo portátil/iPod/reproductor de MP3 y el otro al conector de ENTRADA del panel de control (D).



4. CONEXIÓN A VARIAS SILLAS

Conecte un extremo del cable de audio mini al conector de ENTRADA de la silla 1 (D) y el otro al conector de SALIDA de la silla 2 (E).

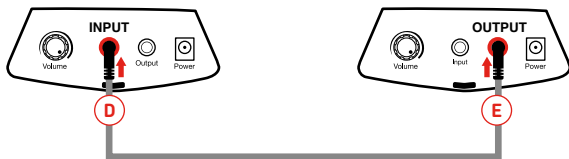

GUÍA DE RESOLUCIÓN DE ERRORES

LA SILLA DE JUEGO RC-3 NO REPRODUCE NINGÚN SONIDO

- 1] **¿Está la silla encendida?** Gire el regulador de volumen en el panel de control y mire si se enciende el LED para comprobar que la silla está encendida.
- 2] **¿Está el cable de audio bien conectado?** Revise detenidamente los cables y asegúrese de que están bien conectados de acuerdo con la guía de conexión. Para conectar la silla de juego a su televisor o dispositivo AV, compruebe que el cable RCA (no incluido) está bien conectado a la salida de audio o para auriculares del televisor o dispositivo AV.
- 3] **Gire el regulador de volumen para asegurarse de que está ajustado en un nivel audible.**
- 4] **Haga pruebas con otra fuente de audio** (reproductor de CD/MP3, televisor, etc.).

Si la silla sigue sin reproducir sonidos tras completar estos pasos, póngase en contacto con nuestro departamento de asistencia técnica.

Este producto tiene un [1] año de garantía. Si desea más información sobre las condiciones o quiere solicitar asistencia técnica, visite este sitio web: gioteck.com/contact-support.

IMPORTANT - Pour garantir un fonctionnement sans risque, veuillez lire ces instructions opérationnelles de sécurité avant toute utilisation :

- Usage intérieur uniquement. Conserver à l'abri de la lumière directe du soleil, de l'humidité et des températures extrêmes.
- Les enfants de moins de 13 ans ne devraient pas utiliser ce produit sans surveillance. Le montage de l'appareil nécessite la présence d'un adulte.
- Ne pas utiliser sur un sol glissant ou instable.
- L'utilisation prolongée de l'équipement audio à volume élevé peut entraîner des pertes d'audition. Utiliser l'équipement de manière responsable.
- Ne pas nettoyer ni tremper dans l'eau l'équipement. En cas de présence d'eau sur l'appareil, le débrancher immédiatement et attendre qu'il soit totalement sec pour l'utiliser à nouveau.
- Conserver dans un endroit sec et sans poussière.
- Ne pas exposer à des températures extrêmement basses (0°C) ou extrêmement élevées (40°C).
- Ne pas salir et éviter tout contact avec l'eau, au risque d'endommager le produit.
- Ne pas démonter l'appareil. Ceci entraînerait l'annulation de la garantie et risquerait de provoquer une décharge électrique ou d'endommager les composants internes.



Préservez l'environnement en recyclant l'emballage carton de ce produit.



Ne jetez pas ce produit avec les ordures ménagères. Déposez-le dans un centre de collecte des déchets électriques.

Pour plus d'informations sur l'installation ou l'utilisation de ce produit, rendez-vous sur

giotek.com/contact-support

COMPOSANTS

- i) Fauteuil
- ii) Adaptateur audio 3,5 mm/RCA
- iii) Câble mini-audio 3,5 mm
- iv) Adaptateur CA/CC 9 V 600 mA

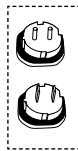
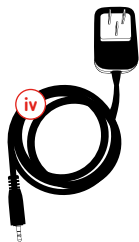
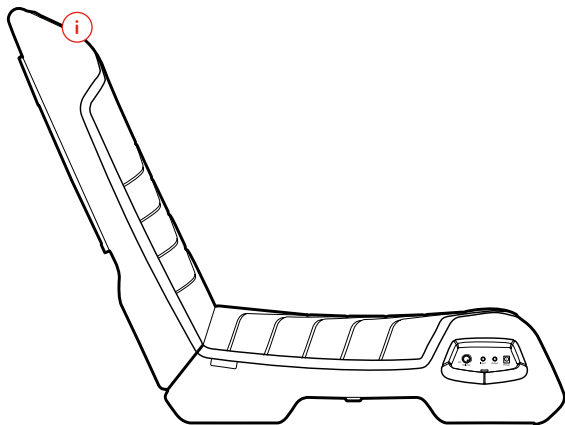

En option

COMMANDES

FR

Bouton marche/arrêt et volume +/-

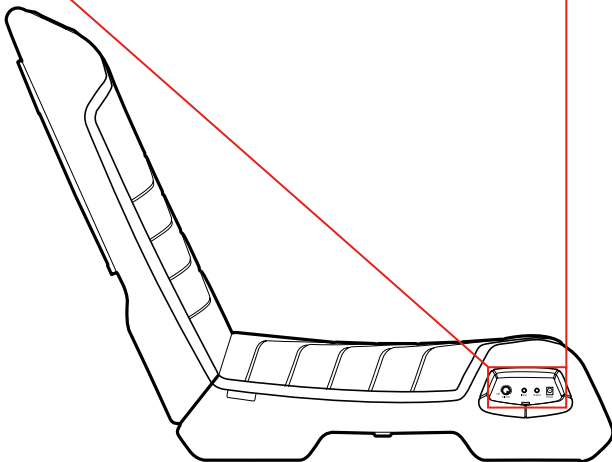
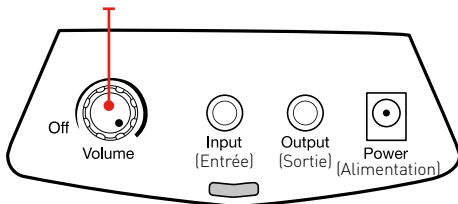

RÉGLAGE DU DOSSIER

Pour incliner le dossier, retirez le bloc rouge sous le dossier du fauteuil, comme indiqué sur le schéma ci-contre.

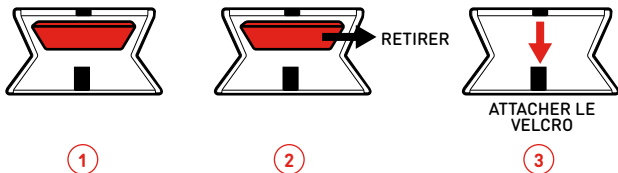
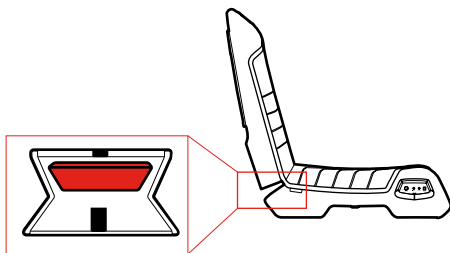
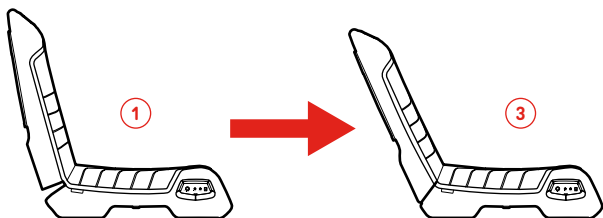

1. CONNEXION À UNE CONSOLE XBOX 360™, PS3™ ET WII™

- 1) Connectez le câble RCA à l'entrée vidéo de votre choix (A).
- 2) Connectez les prises rouge et blanche du câble RCA (non fourni, mais généralement vendu avec la console de jeu) dans les ports correspondants de l'adaptateur RCA (B).
- 3) Connectez une extrémité du câble mini-audio dans l'adaptateur RCA (C) et l'autre extrémité dans la fiche ENTRÉE (INPUT) du panneau de commande (D). L'autre extrémité de ce câble est branchée à la prise AV de votre Xbox.

Remarque destinée aux utilisateurs de Xbox 360™ : en fonction du modèle de votre console et si cette dernière est connectée à une source vidéo par un câble HDMI, vous aurez besoin d'un adaptateur AV/RCA et d'un câble RCA mâle, comme indiqué dans le schéma d'installation 2A ci-dessous.

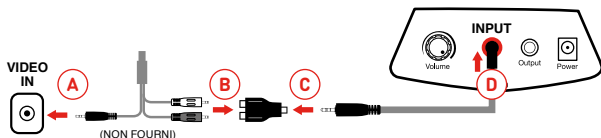

2A. CONNEXION À UNE CONSOLE XBOX ONE™, PS4™, TV, LECTEUR DVD, BOX

- 1) Connectez le câble RCA mâle/mâle (non fourni) à la sortie audio de votre choix (A).
- 2) Connectez les autres extrémités du câble RCA dans les ports correspondants de l'adaptateur RCA (B).
- 3) Connectez une extrémité du câble mini-audio dans l'adaptateur RCA (C) et l'autre extrémité dans la fiche ENTRÉE (INPUT) du panneau de commande (D).

Tous les téléviseurs ne sont pas équipés de sorties audio gauche et droite. Vérifiez à l'arrière de votre téléviseur s'il est équipé d'une sortie pour casque audio. Si votre téléviseur dispose d'une sortie pour casque audio, les étapes A, B et C ne sont pas nécessaires pour cette installation, et le câble audio fourni avec le fauteuil peut être directement relié à la sortie pour casque audio du téléviseur.

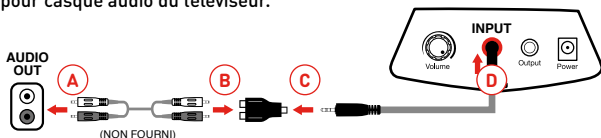

2B. CONNEXION À UNE CONSOLE PS4™ & XBOX ONE™

Connectez une extrémité du câble mini-audio dans la fiche de la manette (A) et l'autre extrémité dans la fiche ENTRÉE (INPUT) du panneau de commande (D).

- Le volume audio sera moins puissant avec cette installation que celle décrite au point 2A.
- Utilisez un adaptateur de casque stéréo Microsoft® avec votre manette Xbox One™.
- Si vous utilisez une PS4™, vous devrez modifier les paramètres de votre console : Paramètres > Changer "Chat uniquement" en "Tous les sons".

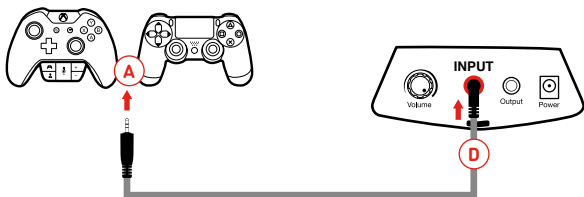

3. CONNEXION À UN APPAREIL MOBILE / IPOD / LECTEUR MP3

Connectez une extrémité du câble mini-audio dans la sortie casque (A) de votre appareil mobile / iPod / lecteur MP3 et l'autre extrémité dans la fiche ENTRÉE (INPUT) du panneau de commande (D).



4. CONNEXION À PLUSIEURS FAUTEUILS

Connectez une extrémité du câble mini-audio dans la fiche ENTRÉE (INPUT) du fauteuil 1 (D), et l'autre extrémité dans la fiche SORTIE (OUTPUT) du fauteuil 2 (E).



RÉSOLUTION DES PROBLÈMES

LE FAUTEUIL DE JEU RC-3 N'ÉMET AUCUN SON.

- 1] **Le fauteuil de jeu est-il allumé ?** Vérifiez que le fauteuil de jeu est alimenté. Pour ce faire, tournez le bouton de volume sur le panneau de contrôle, et vérifiez que la LED s'allume.
- 2] **Le câble audio est-il correctement connecté ?** Vérifiez les différents branchements selon les instructions de montage. Pour connecter le fauteuil de jeu à une source TV ou AV, les câbles RCA (non fournis) DOIVENT être connectés à la sortie audio ou casque de votre source TV ou AV.
- 3] **Tournez le bouton de contrôle de volume pour vous assurer que le son est réglé à un niveau audible.**
- 4] **Testez une autre source audio** (lecteur CD, téléviseur, lecteur MP3, etc.).
Si, après avoir suivi les instructions ci-dessus, le son reste inaudible, contactez notre assistance technique.

Ce produit est couvert par une garantie d'un [1] an. Conditions d'utilisation et assistance technique disponibles sur gioteck.com/contact-support

IMPORTANTE: Para garantir uma utilização sem riscos, antes de utilizar por favor leia estas Orientações sobre Utilização e Segurança:

- Apenas para utilizar em espaços fechados. NÃO expor a luz solar direta, humidade ou temperaturas extremas.
- Crianças com idade inferior a 13 anos não devem utilizar este produto sem supervisão parental. A supervisão de adultos é necessária para a montagem.
- NÃO utilize em pavimento escorregadio ou desnivelado.
- O uso excessivo de equipamentos de áudio com um volume elevado pode levar à perda de audição. Ouça com responsabilidade e use o senso comum.
- NÃO lave com água nem mergulhe esta unidade em água. Se a cobertura ficar molhada, desligue da alimentação imediatamente e não volte a utilizar até que se encontre completamente seca.
- Guarde numa área seca e sem pó.
- Não guarde em áreas sujeitas a temperaturas extremamente baixas (0°C) ou altas (40°C).
- Não deixe o produto ficar molhado nem sujo; pois poderá causar danos.
- Não desmonte o produto; ao fazê-lo estará a invalidar a sua garantia e poderá causar choques elétricos ou danos aos componentes internos.



Por favor, ajude a conservar o ambiente ao reciclar a caixa de cartão deste produto.



Este produto NÃO deve ser eliminado através do lixo normal. Deve eliminá-lo separadamente. Por favor, coloque-o a num ponto de coleta de lixo elétrico.

Se necessitar de ajuda na configuração ou utilização deste produto, por favor aceda a:

giotek.com/contact-support

PEÇAS

- i] Cadeira
- ii] Adaptador 3,5 mm para RCA
- iii] Mini cabo áudio de 3,5 mm
- iv] Adaptador DC de 9V 600 mA

PT

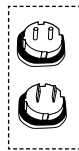
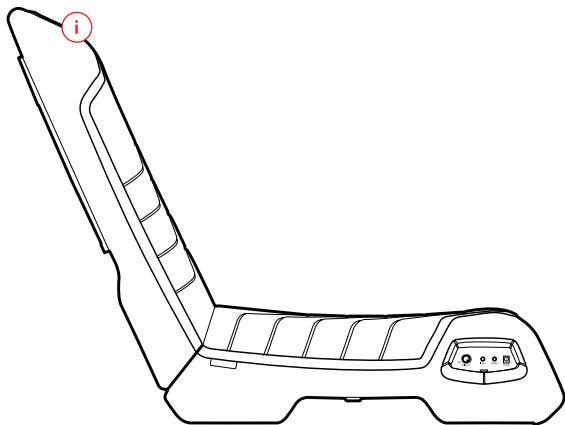

opcional

CONTROLOS

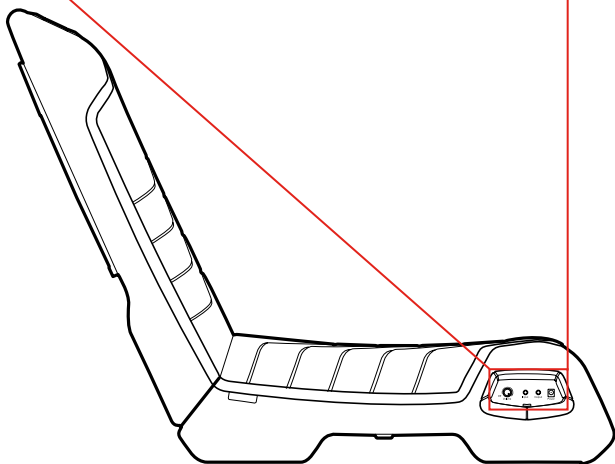
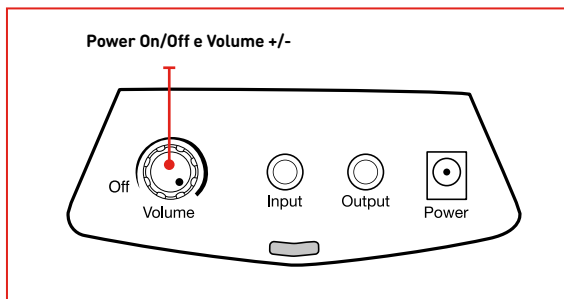

AJUSTE DAS COSTAS

Para uma posição da cadeira mais confortável. Remova o bloco vermelho por baixo da cadeira como demonstrado,

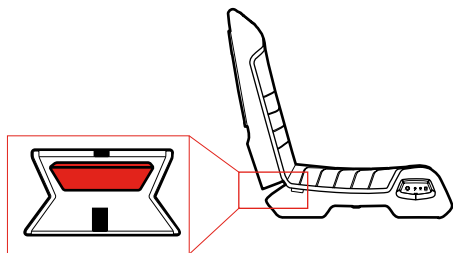
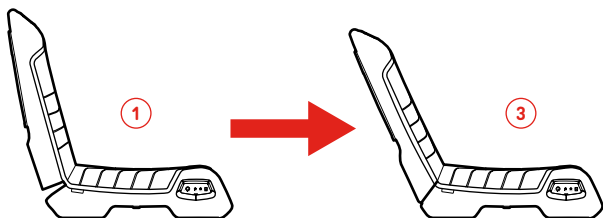

1. LIGAÇÃO À XBOX 360™, PS3™, WII™

- 1) Conecte o cabo RCA à entrada de vídeo (VIDEO INPUT) escolhida (A).
- 2) Conecte a cabeça vermelha e branca do cabo RCA (não incluído, mas normalmente fornecido com a sua consola de jogos) às portas correspondentes do adaptador RCA (B).
- 3) Conecte um terminal do mini cabo de áudio ao adaptador RCA (C) e o outro terminal à porta de entrada (INPUT) do painel de controlo (D). A outra ponta deste cabo é ligada à porta AV da Xbox.

Nota para os Utilizadores de Xbox 360™ : Dependendo do modelo da sua consola, e se a sua consola estiver conectada através de HDMI à fonte de vídeo, terá de adquirir um adaptador AV RCA e utilizar o cabo RCA macho para macho, como demonstrado em 2A abaixo.

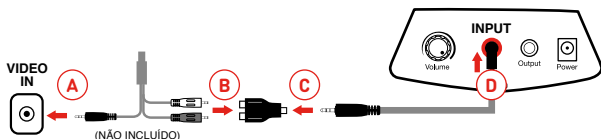

2A. CONEXÃO À XBOX ONE™, PS4™, TV, DVD, RECETOR

- 1) Conecte o cabo RCA macho para macho (não incluído) à sua fonte de saída de áudio (AUDIO OUT) escolhida (A).
- 2) Conecte os outros terminais do cabo RCA às portas correspondentes do adaptador RCA (B).
- 3) Conecte um dos terminais do mini cabo de áudio ao adaptador RCA (C) e o outro terminal à porta de entrada (INPUT) do painel de controlo (D).

Nem todos os Televisores/Monitores têm Saída de Áudio Esquerda e Direita. Procure atrás do Televisor/Monitor e veja se existe uma porta de Saída para Auriculares. Se a sua TV possui uma saída de Auscultador A, os passos B e C não são necessários, e o cabo de áudio fornecido com a cadeira pode ser conectado diretamente à porta de auscultador da TV.

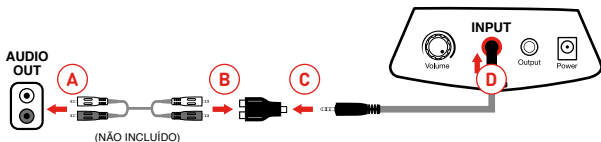

2B. CONEXÃO À PS4™ E XBOX ONE™

Conecte um dos terminais do mini cabo de áudio à porta do controlador (A) e o outro terminal à porta de entrada (INPUT) do painel de controlo (D).

- O volume do som vai estar mais baixo nesta configuração em comparação à configuração 2A.
- Assegure-se de que está a utilizar o Adaptador Microsoft® Headset Stereo com o seu comando da Xbox One™.
- Se estiver a usar uma PS4™, terá de modificar as configurações na sua consola: Configurações > 'Só Chat' (Chat Only) para 'Todo o Som' (All Sound).

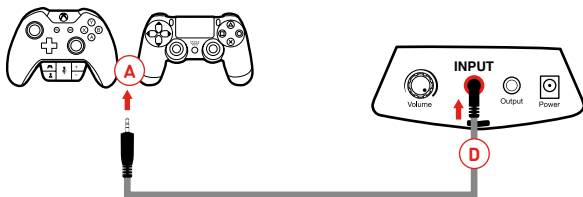

3. CONEXÃO AO DISPOSITIVO PORTÁTIL /IPOD / MP3

Conecte um dos terminais do mini cabo de áudio à porta de auriculares (A) do seu dispositivo portátil/iPOD/leitor de MP3 e o outro terminal à porta de entrada (INPUT) do painel de controlo (D).



4. CONEXÃO A MÚLTIPLAS CADEIRAS

Conecte um terminal do mini cabo de áudio à porta de entrada (INPUT) da Cadeira 1 (D) e o outro terminal à porta de saída (OUTPUT) da Cadeira 2 (E).



RESOLUÇÃO DE PROBLEMAS

NÃO SE RECEBE SOM DA CADEIRA DE JOGO RC-3

- 1] **A cadeira de jogo está ligada (ON)?** Verifique para garantir que a cadeira de jogo está ligada, ajustando o botão de volume no painel de controlo e a luz LED deverá acender.
- 2] **O cabo de áudio está ligado corretamente?** Verifique a conexão dos seus cabos com atenção e garanta que todos os cabos estão corretamente conectados conforme o Guia de Conexão. Para conectar a cadeira de jogo com o Televisor ou fonte AV, os cabos RCA (não incluídos) DEVEM estar conectados à Saída de Áudio ou Auriculares do Televisor ou fonte AV.
- 3] **Ajuste o botão de Volume para garantir que o áudio se encontra num nível audível.**
- 4] **Teste com várias fontes de áudio alternativas** (leitor de CD, Televisor, MP3, etc.)

Se depois de completar todos os passos acima descritos ainda não existir som, por favor, contacte-nos para assistência.

Este produto está coberto pela garantia de um [1] ano. Para saber quais os Termos e Condições completos, e para Assistência Técnica, acesse a:

gioteck.com/contact-support

ATTENZIONE: per evitare di correre rischi durante il funzionamento, leggere le presenti istruzioni per l'uso e la sicurezza prima di iniziare a utilizzare il prodotto.

- Il prodotto deve essere utilizzato esclusivamente in luoghi chiusi. EVITARE l'esposizione diretta ai raggi solari, all'umidità e a temperature estreme.
- I ragazzi di età inferiore ai 13 anni non dovrebbero usare questo prodotto senza la supervisione di un genitore. Per l'installazione è necessaria la supervisione di un adulto.
- NON utilizzare su pavimenti scivolosi o irregolari.
- Un uso eccessivo di attrezzature audio a volume elevato può portare alla perdita dell'udito. Ascoltare in modo responsabile e usando buon senso.
- NON lavare o impregnare con acqua il prodotto. Nel caso in cui il prodotto venisse a contatto con liquidi, scollegarlo immediatamente dalla corrente elettrica e aspettare che si asciughi completamente.
- Conservare in un luogo asciutto e lontano dalla polvere.
- Non conservare in luoghi con temperature estremamente basse (0 °C) o estremamente elevate (40 °C).
- Non bagnare o sporcare il prodotto, poiché in tal caso potrebbe danneggiarsi.
- Non smontare il prodotto, poiché in tal caso si annulla la garanzia e possono verificarsi scariche elettriche o danni ai componenti interni.



Riciclare la confezione in cartoncino del prodotto per tutelare l'ambiente.



Questo prodotto NON deve essere smaltito insieme ai normali rifiuti domestici, bensì separatamente. Si prega di consegnarlo a un centro di raccolta di rifiuti di apparecchiature elettriche ed elettroniche.

Per assistenza con l'installazione o il funzionamento di questo prodotto, visitare il sito Web

giotek.com/contact-support

ELENCO DEI COMPONENTI

- i) Sedia
- ii) Adattatore RCA da 3,5 mm
- iii) Cavo audio mini da 3,5 mm
- iv) Adattatore CC da 9 V, 600 mA

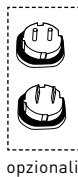
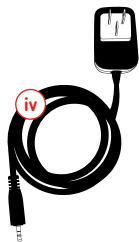
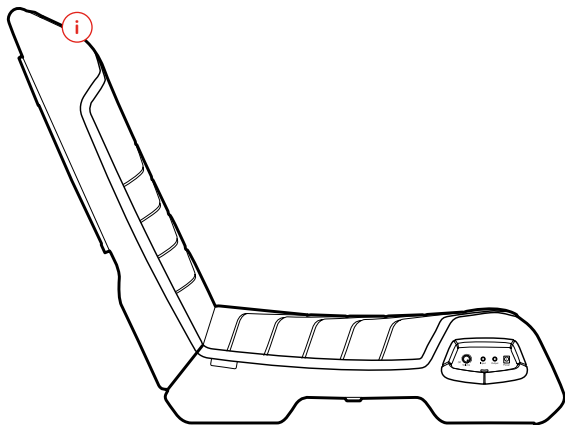

COMANDI

Accensione/Spegnimento e Volume +/-

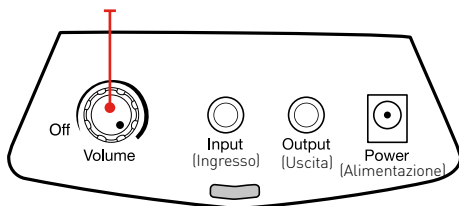

IT

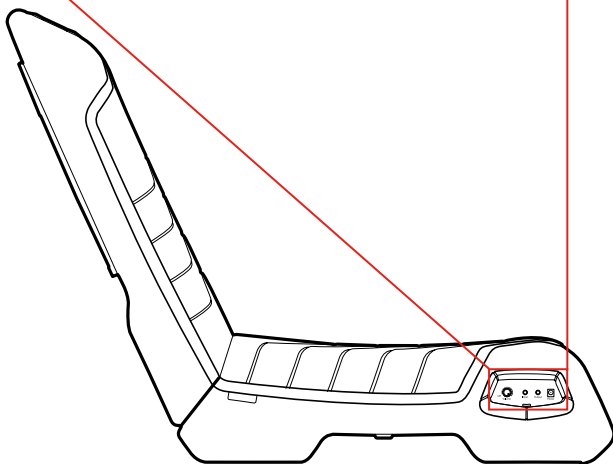

REGOLARE LO SCHIENALE

Per ottenere una posizione dello schienale più comoda: rimuovere il blocco rosso dalla parte bassa dello schienale, come mostrato nelle figure.

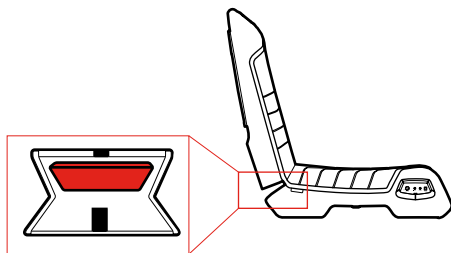
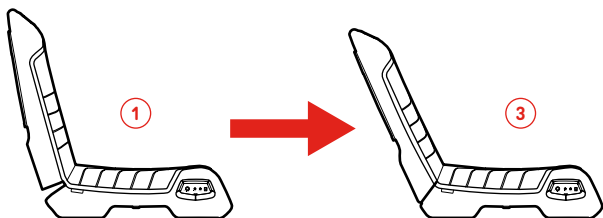

1. COLLEGAMENTO A XBOX 360™, PS3™, WII™

- 1) Collegare il cavo RCA all'ingresso video preferito (A).
- 2) Collegare le estremità rossa e bianca del cavo RCA (non incluso, ma di solito fornito con la console di gioco) alle porte corrispondenti dell'adattatore RCA (B).
- 3) Collegare un'estremità del cavo audio mini all'adattatore RCA (C) e l'altra estremità alla presa INPUT del pannello di controllo (D). L'altra estremità di questo cavo è inserita nella presa AV sulla tua Xbox.

Nota per gli utenti di Xbox 360™ : a seconda del modello della console e del suo eventuale collegamento a una sorgente video tramite HDMI, sarà necessario procurarsi un adattatore RCA AV e utilizzare un cavo RCA maschio-maschio come quello mostrato nella figura del paragrafo 2A qui sotto.

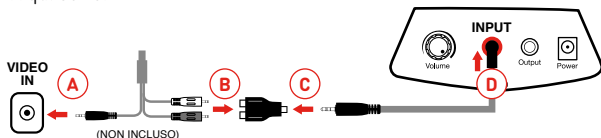

2A. COLLEGAMENTO A XBOX ONE™, PS4™, TV, DVD, RICEVITORE

- 1) Collegare il cavo RCA maschio-maschio (non incluso) all'uscita audio preferita (A).
- 2) Collegare le altre estremità del cavo RCA alle porte corrispondenti dell'adattatore RCA (B).
- 3) Collegare un'estremità del cavo audio mini all'adattatore RCA (C) e l'altra estremità alla presa INPUT del pannello di controllo (D).

Non tutti i televisori/monitor hanno un'uscita audio destra e sinistra. Osservare la parte posteriore del televisore/monitor e controllare se dispone di un'uscita per le cuffie: Se la tua TV dispone di un'uscita per le cuffie, non sarà necessario seguire i punti A, B e C per questa configurazione e il cavo audio fornito insieme alla sedia potrà essere inserito direttamente nella presa TV per le cuffie.

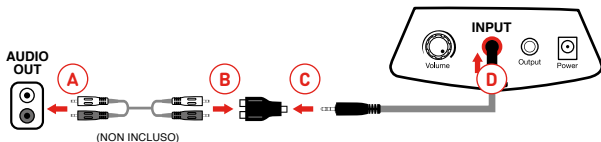

2B. COLLEGAMENTO A PS4™ E XBOX ONE™

Collegare un'estremità del cavo audio mini alla presa del controller (A) e l'altra estremità alla presa INPUT del pannello di controllo (D).

- Il volume dell'audio sarà più basso usando questa configurazione, piuttosto che quella illustrata nel paragrafo 2A.
- Assicurarsi di usare un adattatore cuffie stereo di Microsoft® con il controller di Xbox One™.
- Se si usa un PS4™, sarà necessario cambiarne le impostazioni: Impostazioni > Cambiare da "Solo chat" a "Tutto l'audio".

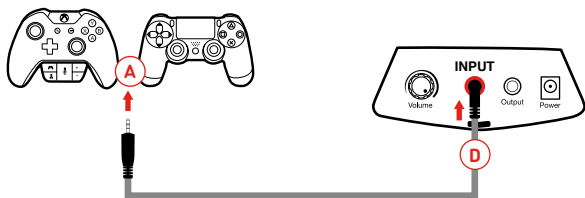

3. COLLEGAMENTO A DISPOSITIVI PORTATILI/IPOD/LETTORI MP3

Collegare un'estremità del cavo audio mini alla presa per le cuffie (A) del dispositivo portatile/iPod/lettore MP3 e l'altra estremità alla presa INPUT del pannello di controllo (D).



4. COLLEGAMENTO A PIÙ SEDIE

Collegare un'estremità del cavo audio mini alla presa INPUT della Sedia 1 (D) e l'altra estremità alla presa OUTPUT della Sedia 2 (E).

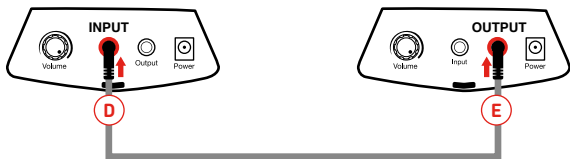

GUIDA ALLA RISOLUZIONE DEI PROBLEMI

DALLA SEDIA DI GIOCO RC-3 NON PROVIENE ALCUN SUONO

- 1] La sedia di gioco è accesa? Regolare la manopola del volume sul pannello di controllo per verificare che la sedia di gioco sia accesa; se lo è, il LED si illuminerà.
- 2] Il cavo audio è collegato correttamente? Controllare che il cavo audio sia collegato correttamente e assicurarsi che anche tutti gli altri i cavi siano collegati secondo quanto riportato nelle istruzioni. Per collegare la sedia di gioco al televisore o alla sorgente AV, i cavi RCA (non inclusi) DEVONO essere collegati all'uscita audio o per le cuffie del televisore o della sorgente AV.
- 3] Regolare la manopola del volume per assicurarsi che l'audio sia a un livello udibile.
- 4] Eseguire delle prove con una sorgente audio differente (lettore CD, TV, lettore MP3, ecc.).

Se dopo aver completato tutti questi passaggi dalla sedia non proviene ancora alcun suono, contattare il produttore per ricevere assistenza.

Questo prodotto è coperto da un (1) anno di garanzia.

Per consultare tutti i termini e le condizioni e per ricevere assistenza tecnica, visitare il sito Web gioteck.com/contact-support



Gioteck hereby declare that this product is in compliance with the essential requirements and other provision of Directive 2004/108/EC e R&TTe 1999/5/EC.

Par ce document, Gioteck déclare ce produit conforme aux critères fondamentaux et autres dispositions de la Directive 2004/108/EC et R&TTe 1999/5/EC.

Gioteck erklärt hiermit, dass dieses produkt die Grundanforderungen sowie weitere Vorschriften der Richtlinie 2004/108/EC und R&TTe 1999/5/EC.

Gioteck declara que este producto cumple los requisitos esenciales y demás disposiciones de la Directiva 2004/108/EC y R&TTe 1999/5/EC.

Gioteck dichiara che questo prodotto soddisfa i requisiti essenziali e altre clausole della direttiva 2004/108/EC e R&TTe 1999/5/EC.

Gioteck declara que este producto os requisitos essenciais e outras provisões da Diretiva 2004/108/EC e R&TTe 1999/5/EC

This device complies with Industry Canada RSS 210 standard(s). Operation is subject to the following two conditions: (1) this device may not cause interference, and (2) this device must accept any interference, including interference that may cause undesired operation of the device.

Le présent appareil est conforme aux CNR d'Industrie Canada applicables aux appareils radio exempts de licence. L'exploitation est autorisée aux deux conditions suivantes : (1) l'appareil ne doit pas produire de brouillage, et (2) l'utilisateur de l'appareil doit accepter tout brouillage radioélectrique subi, même si le brouillage est susceptible d'en compromettre le fonctionnement.

Complies with
IDA Standards
DB100398





This device complies with Part 15 of the FCC Rules. Operation is subject to the following two conditions: (1) this device may not cause harmful interference, and (2) this device must accept any interference received, including interference that may cause undesired operation. However, there is no guarantee that interference will not occur in a particular installation. The device and its antenna must not be co-located or operating in conjunction with any other antenna or transmitter. Gioteck are not responsible for any interference caused by un-authorized changes to this equipment. This equipment generates, uses, and can radiate radio frequency energy and, if not installed correctly, may cause harmful interference to radio communications. This equipment has been tested and found to comply with the limits for a Class B digital device, pursuant to part 15 of the FCC Rules. These limits are designed to provide reasonable protection against harmful interference in a residential installation. If this equipment does cause harmful interference to radio or television reception, which can be determined by turning the equipment off and on, the user is encouraged to try to correct the interference by one or more of the following measures:

- Reorient or relocate the receiving antenna.
- Increase the separation between the equipment and receiver.
- Connect the equipment into an outlet on a circuit different from that to which the receiver is connected.
- Consult the dealer or an experienced radio/TV technician for help.

gioteck ™